

July 30,2010

Enplas Corporation

2011/3

First Quarter Results

Director
Takashi Sakai

2011/3 Management Policy

1. Provide services and value appreciated by Customer
2. Strengthen the foundation of global business
3. Confirm and Build up Enplas' corporate DNA

Account Results and Revised Plan					
(100 Million Yen)					
	2010/3 Results	2011/3 Plan	2011/3 Revised Plan	2011/3 First-Half Revised Plan	First-Quarter Results
Net Sales	182.2	210.0	220.0	(110.0)	58.6
(COGS Ratio)	(65.8%)	(60.0%)	(58.2%)	(58.2%)	(60.5%)
Operating Income	6.8	19.0	26.0	(13.0)	6.5
Ordinary Income	6.5	20.0	26.0	(13.0)	6.5
Net Income	2.5	11.0	14.0	(7.0)	3.9
Net Income Per Share	16.71Yen	71.79Yen	91.37Yen	(45.69Yen)	26.00Yen
Dividends Per Share	12.50Yen	15.00Yen	15.00Yen	(7.50Yen)	-

3

Quarterly Account Results					
(100 Million Yen)					
	2010/3				2011/3
	First Quarter	Second Quarter	Third Quarter	Fourth Quarter	First-Quarter Results
Net Sales	35.0	45.1	49.7	52.2	58.6
(COGS Ratio)	(73.6%)	(67.1%)	(63.8%)	(61.5%)	(60.5%)
Operating Income	4.3	1.1	4.0	5.9	6.5
Ordinary Income	4.2	0.9	4.3	5.4	6.5
Net Income	4.9	0.5	2.5	4.3	3.9
Net Income Per Share	32.23Yen	3.75Yen	16.85Yen	28.67Yen	26.00Yen

4

Quarterly Ordinary Income Margin Transition

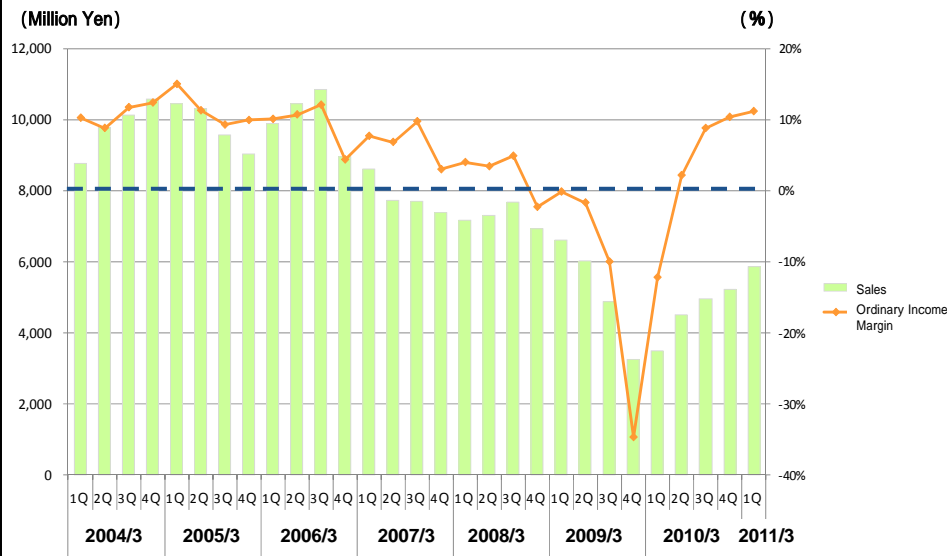

Quarterly Sales Results by Segment

(100 Million Yen)

	2010/3				2011/3
	First Quarter	Second Quarter	Third Quarter	Fourth Quarter	First-Quarter Results
Engineering Plastic Products	18.9	26.4	30.9	28.6	30.6
Semiconductor Peripherals	6.8	7.5	9.2	11.3	14.2
Plastic Optics (LED Business inclusive)	9.3	11.2	9.6	12.2	13.7
Total	35.0	45.1	49.7	52.2	58.6

Revised Sales Plan by Segment					
					(100 Million Yen)
	2010/3 Results	2011/3 Plan	2011/3 Revised Plan	2011/3 First-Half Revised Plan	First-Quarter Results
Engineering Plastic Products	104.9	114.0	120.0	(60.0)	30.6
Semiconductor Peripherals	34.9	40.0	47.0	(26.0)	14.2
Plastic Optics (LED Business inclusive)	42.3	56.0	53.0	(24.0)	13.7
Total	182.2	210.0	220.0	(110.0)	58.6

7

Account Results by Segment				
				(100 Million Yen)
	Engineering Plastic Products Business	Semiconductor Peripherals Business	Plastic Optics Business (LED Business inclusive)	
Net Sales	30.6	14.2	13.7	
(COGS Ratio)	(65.7%)	(53.8%)	(56.2%)	
Operating Income	2.8	2.9	0.7	

8

Other Significant Indices				
	2010/3 Results	2011/3 Plan	(100 Million Yen)	
			First-Quarter Results	
<u>Facility Investment</u>	7.4	12.0	2.0	
<u>Depreciation</u>	13.7	15.0	3.5	
<u>Research and Development Expenses</u>	4.5	5.0	1.3	
<u>(Ratio to sales)</u>	(2.5%)	(2.4%)	(2.3%)	

9



**Business Strategy and Plan
for Each Segment**

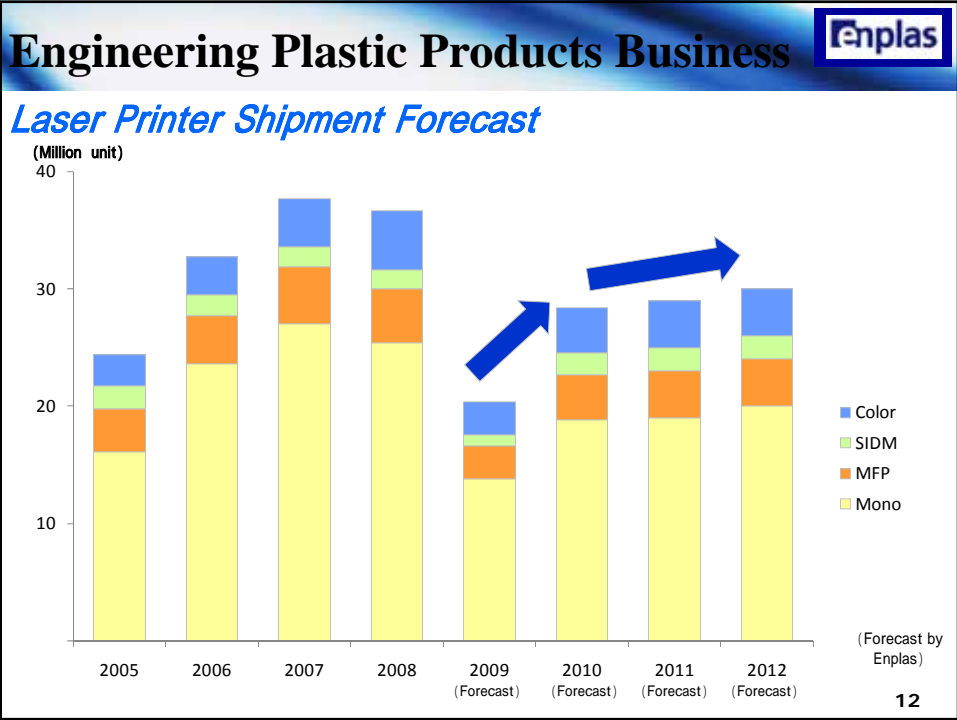
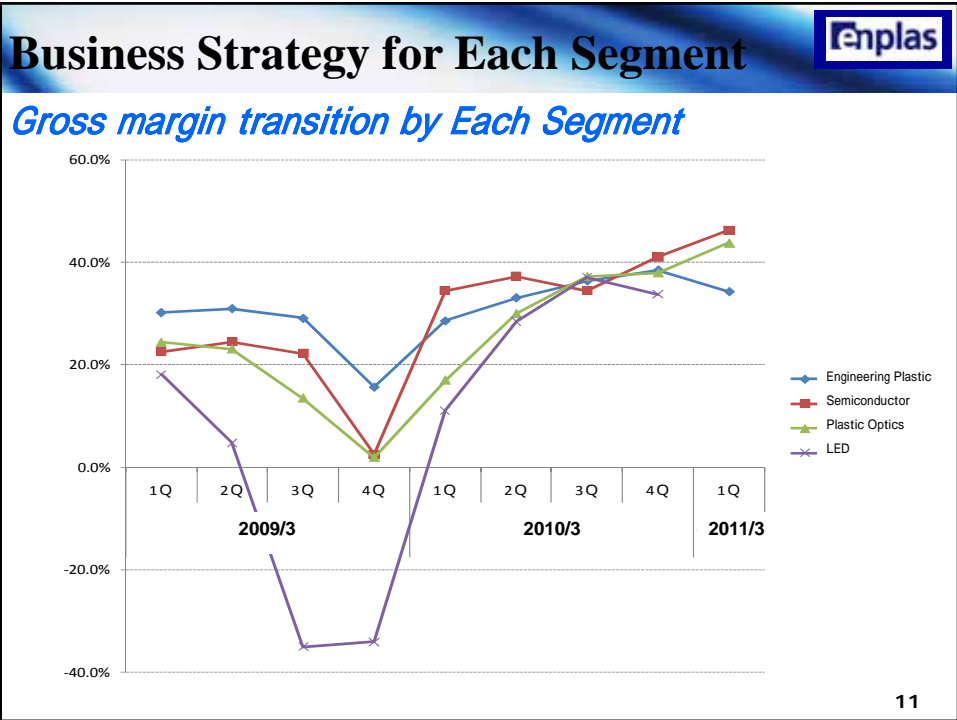

Engineering Plastic Products Business

Auto Parts Market Forecast Global

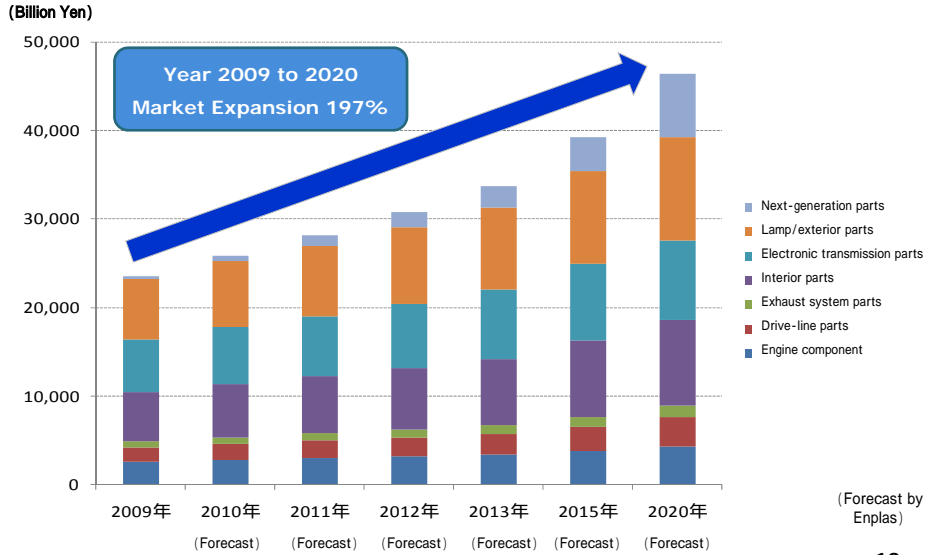

Semiconductor Peripherals Business

Semiconductor Shipment Value Forecast

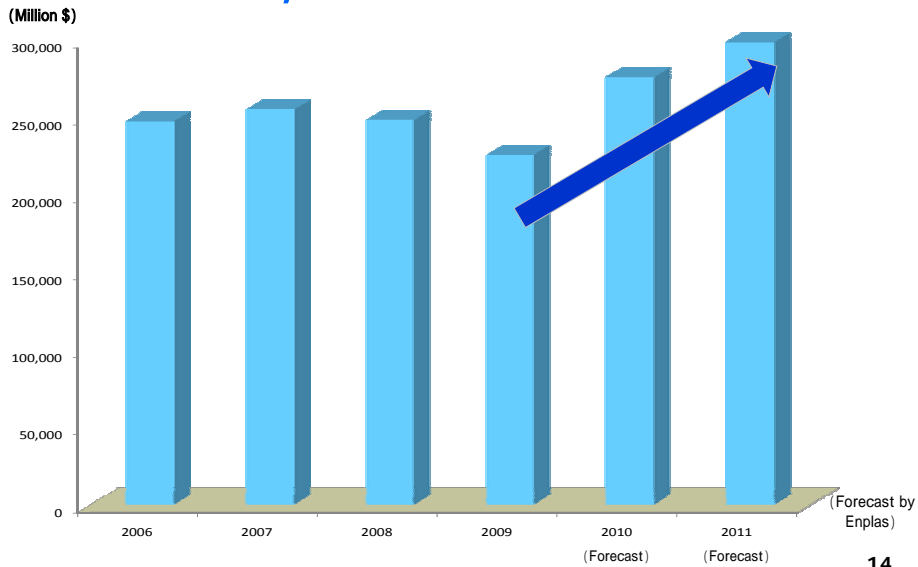

Semiconductor Peripherals Business



Socket for Server Market Forecast

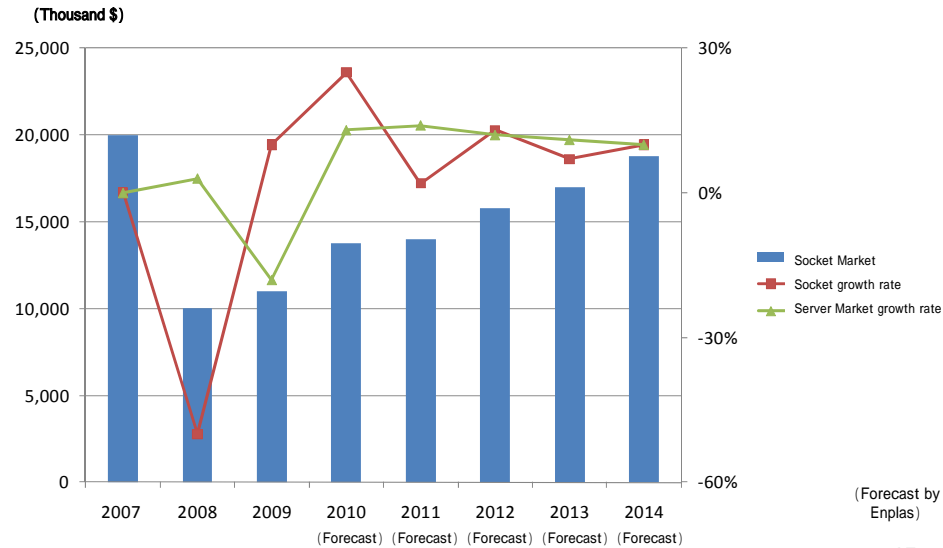

Plastic Optics Business –LED –



LED penetration rate for LCD TV by region Forecast

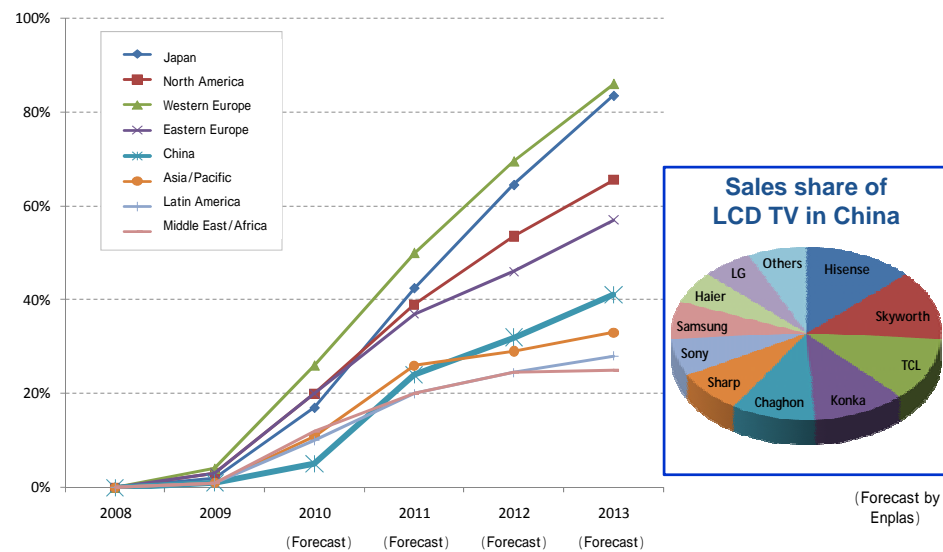

Plastic Optics Business –OFC –



Future Expansion - Transmission speed and products

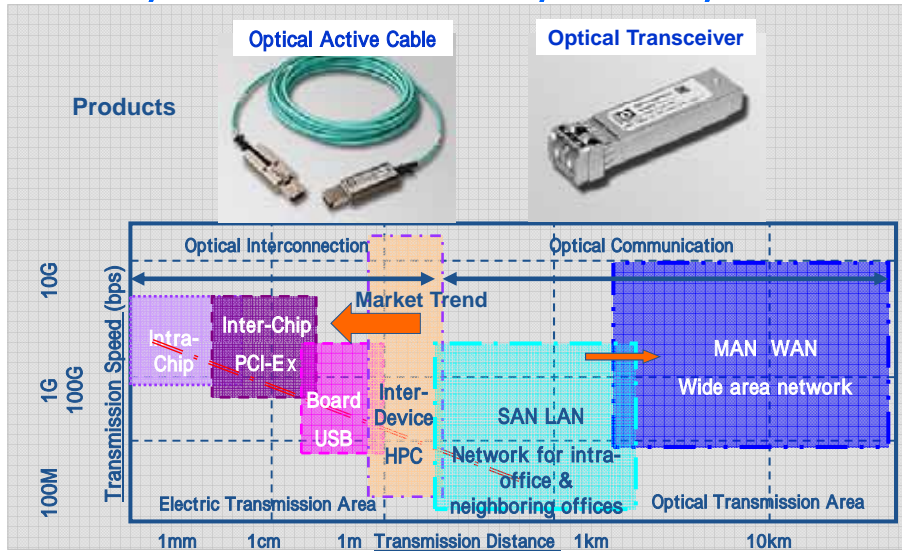

Plastic Optics Business –OFC –



Plastic Lens Market Expansion for Optical Communication

High-Capacity communication needs by expanding cloud computing market and large-scale server



Optical Connector needs for high-capacity communication



More high precision and small-size Plastic lens needs





Thank you for your attention.

Enplas Corporation