

# TSOP

## THIN SMALL OUTLINE PACKAGE

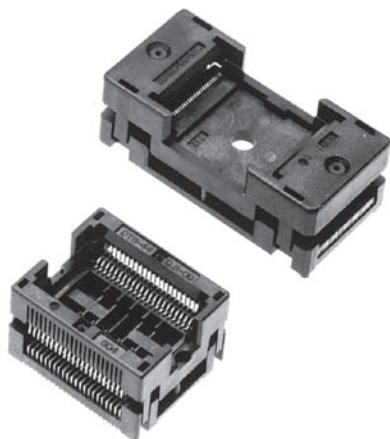

### ORDERING PROCEDURE

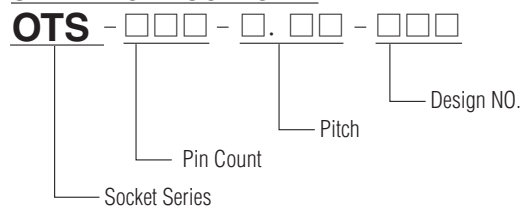

Specification / 仕様	
Contact resistance (Initial) 接触抵抗 (初期値)	30mΩ · 50mΩ · 100mΩ (At 10 mA)
Maximum voltage 耐電圧	AC700V RMS (for 1 minute) Below 0.5mm Pitch AC500V RMS (for 1 minute)
Insulation resistance 絶縁抵抗	1,000MΩ or higher (At DC 500V)
Rated current 許容電流値	1A
Operating temperature range 仕様温度	-65°C ~ +150°C
Terminal strength against pulling 端子抜け強度	0.5kg (1 min)
Insertion 機械寿命	Min. 5,000 times, 10,000 times (mechanical)
MATERIAL / 材質	
Body 本体	PEI, PES
Contact コンタクトピン	BeCu, Au plating (Ni-base)

※RoHS compliant

※PINCH CONTACT: Patent No. 1869849 (Japan) Patent No. 4691975 (U.S.A.)

## APPLICABLE IC DIMENSIONS & SOCKET DIMENSIONS

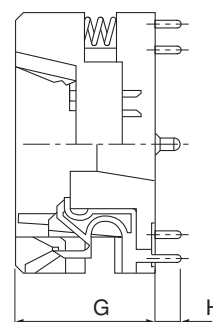
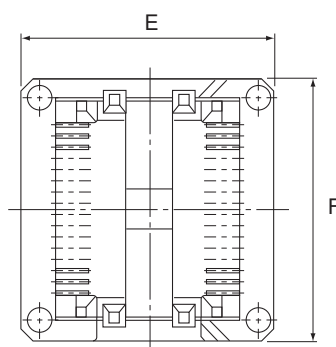
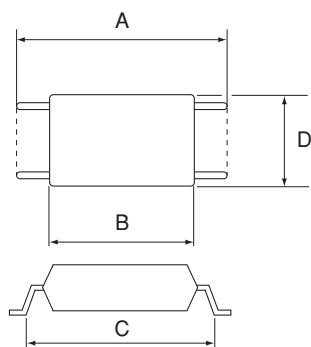

# Applicable IC/TSOP

## OPEN TOP TYPE SOCKET

### TSOP TYPE I (PINCH CONTACT)

PART NO.	PIN COUNT	PITCH	ACTUATION FORCE	APPLICABLE IC DIMENSIONS (REF.)				OUTSIDE DIMENSIONS(REF.)				REMARKS
				A	B	C	D	E	F	G	H	
OTS-32-0.5-09	32	0.5 (19.6mil)	max 1.2kg	20 (0.787)	18.4 (0.724)	19 (0.748)	8.23 (0.324)	40 (1.575)	14 (0.551)	14.3 (0.563)	3.6 (0.142)	8×20
OTS-48-0.5-03	48	0.5 (19.6mil)	max 1.8kg	20 (0.787)	18 (0.724)	19 (0.748)	12 (0.472)	38 (1.496)	20 (0.787)	14.3 (0.563)	3.2 (0.126)	12×20
OTS-48-0.5-09	48	0.5 (19.6mil)	max 1.8kg	18±0.1 (0.708)	16.4±0.05 (0.645)	17±0.1 (0.669)	max12.25 (0.482)	33 (1.299)	20 (0.787)	15.7 (0.618)	2.8 (0.110)	12×18

### TSOP TYPE II (PINCH CONTACT)

PART NO.	PIN COUNT	PITCH	ACTUATION FORCE	APPLICABLE IC DIMENSIONS (REF.)				OUTSIDE DIMENSIONS(REF.)				REMARKS
				A	B	C	D	E	F	G	H	
OTS-24(26)-1.27-14	24	1.27 (50mil)	max 1.0kg	max9.4 (0.370)	max7.77 (0.300)	8.22 (0.324)	max17.44 (0.686)	17.3 (0.681)	22 (0.866)	14.8 (0.583)	3.3 (0.130)	26P-300mil
OTS-28-1.27-21	28	1.27 (50mil)	max 1.1kg	max9.35 (0.368)	max7.68 (0.300)	8.22 (0.324)	max18.52 (0.729)	19.76 (0.778)	23.3 (0.917)	15.4 (0.606)	3.3 (0.130)	28P-300mil
OTS-32-1.27-14	32	1.27 (50mil)	max 1.3kg	max11.89 (0.468)	max10.21 (0.400)	10.76 (0.424)	max21.06 (0.829)	20.2 (0.795)	26 (1.024)	15.4 (0.606)	3.3 (0.130)	32P-400mil
OTS-44-0.8-14	44	0.8 (32mil)	max 1.5kg	max9.32 (0.366)	max7.67 (0.300)	8.22 (0.324)	max18.52 (0.729)	17.66 (0.695)	24 (0.945)	14.8 (0.583)	3.3 (0.130)	44P-300mil
OTS-40(44)-0.8-09	40	0.8 (32mil)	max 1.4kg	max11.89 (0.468)	max10.21 (0.400)	10.76 (0.424)	max18.54 (0.729)	20.2 (0.795)	23.5 (0.925)	14.8 (0.583)	3.3 (0.130)	44P-400mil
OTS-44-0.8-09	44	0.8 (32mil)	max 1.5kg	max11.89 (0.468)	max10.21 (0.400)	10.76 (0.424)	max18.54 (0.729)	20.2 (0.795)	23.5 (0.925)	14.8 (0.583)	3.3 (0.130)	44P-400mil
OTS-44(50)-0.8-17	44	0.8 (32mil)	max 1.6kg	max11.89 (0.468)	10.2 (0.400)	10.76 (0.424)	21.25 (0.836)	20.2 (0.795)	26.4 (1.024)	15.4 (0.606)	3.3 (0.130)	50P-400mil
OTS-52-0.4-01	52	0.4 (15.7mil)	max 2.2kg	10.50 (0.413)	8.9 (0.350)	9.7 (0.382)	11.0 (0.433)	30.51 (1.201)	16.8 (0.651)	14.3 (0.563)	3.3 (0.130)	52P-350mil
OTS-50-0.8-17	50	0.8 (32mil)	max 1.6kg	max11.89 (0.468)	10.2 (0.400)	10.76 (0.424)	21.25 (0.836)	20.2 (0.795)	26.4 (1.024)	15.4 (0.606)	3.3 (0.130)	50P-400mil
OTS-54-0.8-04	54	0.8 (32mil)	max 1.9kg	max11.96 (0.471)	max10.56 (0.416)	10.76 (0.424)	max22.47 (0.855)	20.2 (0.795)	28 (1.102)	14.8 (0.583)	3.3 (0.130)	54P-400mil
OTS-54-0.8-17	54	0.8 (32mil)	max 1.8kg	max11.86 (0.467)	max10.56 (0.416)	10.76 (0.424)	max22.62 (0.891)	19.9 (0.783)	28.1 (1.106)	14.8 (0.583)	3.3 (0.130)	54P-400mil
OTS-54-0.8-18	54	0.8 (32mil)	max 1.8kg	11.76 (0.463)	10.56 (0.416)	10.76 (0.424)	22.22 (0.875)	20.2 (0.795)	28 (1.102)	14.8 (0.583)	3.3 (0.130)	54P-400mil
OTS-66-0.65-04	66	0.65 (26mil)	max 2.1kg	max11.86 (0.467)	max10.56 (0.416)	10.76 (0.424)	max22.52 (0.887)	19.9 (1.209)	37 (1.079)	15.4 (0.606)	3.3 (0.130)	66P-400mil
OTS-66-0.65-07	66	0.65 (26mil)	max 2.0kg	11.76±0.05 (0.463)	10.16±0.05 (0.400)	max11.0 (0.433)	22.22±0.05 (0.875)	21.04 (0.675)	27.41 (1.110)	14.3 (0.563)	3.0 (0.118)	66P-400mil
OTS-66-0.65-08	66	0.65 (26mil)	max 2.8kg	11.76±0.06 (0.463)	10.28±0.03 (0.405)	10.76±0.06 (0.424)	max22.68 (0.893)	20.2 (0.795)	28 (1.102)	15.4 (0.606)	3.3 (0.130)	66P-400mil GTHP
OTS-66-0.65-11	66	0.65 (26mil)	max 1.8kg	11.76±0.06 (0.463)	10.28±0.05 (0.405)	10.76±0.06 (0.424)	max22.68 (0.893)	17.02 (0.670)	28.78 (1.133)	17.8 (0.701)	2.8 (0.110)	Shrink GTHP
OTS-86-0.5-04	86	0.5 (19.6mil)	max 3.0kg	max11.91 (0.469)	max10.56 (0.416)	10.76 (0.424)	max22.27 (0.877)	24.4 (0.783)	27.4 (1.110)	14.8 (0.583)	3.3 (0.130)	86P-400mil

-GTHP : Gas Tight High Pressure